

5d SCFTs, 5-brane webs and (orthosymplectic) Magnetic Quivers

Zhenghao Zhong

In collab with: Antoine Bourget, Julius F Grimminger,
Amihay Hanany and Marcus Sperling
(Imperial College London)

Iberian Strings 2021 January 21st, 2021

[Based on arXiv: 2004.04082]

Supersymmetric Gauge Theories with 8 supercharges

Fields in Lagrangian live in:

- Vector multiplet (vector field, scalar(s), spinors)
 A_μ ϕ
- Hypermultiplet (scalars, spinors)
 q, \tilde{q}^\dagger

Scalar potential

$$V(\phi, q, \tilde{q}^\dagger) = 0$$

Supersymmetric vacuum

Space of solutions \longrightarrow Moduli space of vacua

Moduli space of vacua parameterized by:

- VEVs of scalars (ϕ) in v-plet: Coulomb branch
- VEVs of scalars (q, \tilde{q}^\dagger) in h-plet: Higgs branch
- Both: Mixed branch

$5d \mathcal{N} = 1$ Gauge theory

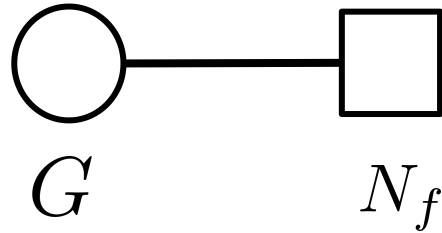

We want to study the Higgs branch of $5d \mathcal{N} = 1$ theories:

- Finite gauge coupling (g_{fin})
- Infinite gauge coupling (g_{∞})

Mission

$5d \mathcal{N} = 1$ theories



Explore the Higgs branch

Introducing the *Magnetic Quiver*

Coulomb branch



$$\mathcal{H}^{5d} \mathcal{N}=1 \left(\begin{array}{c} \bigcirc \text{---} \square \\ G \quad N_f \end{array} \right) = \mathcal{C}^{3d} \mathcal{N}=4 \text{ (Magnetic Quiver)}$$

Higgs branch



Mission (Updated)

$5d \mathcal{N} = 1$ theories



Find Magnetic Quiver



Explore the Higgs branch

$$5d \mathcal{N} = 1$$

Gauge theory (g_{fin})

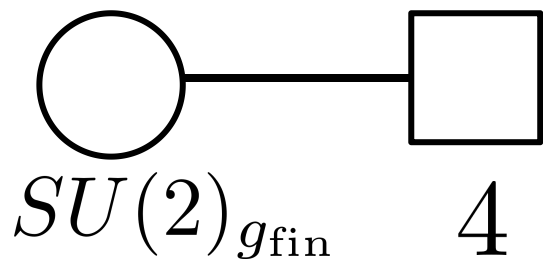

Coulomb
branch

Higgs
branch

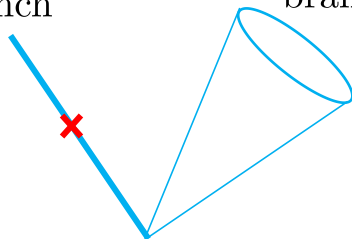

Coulomb branch
Brane configuration

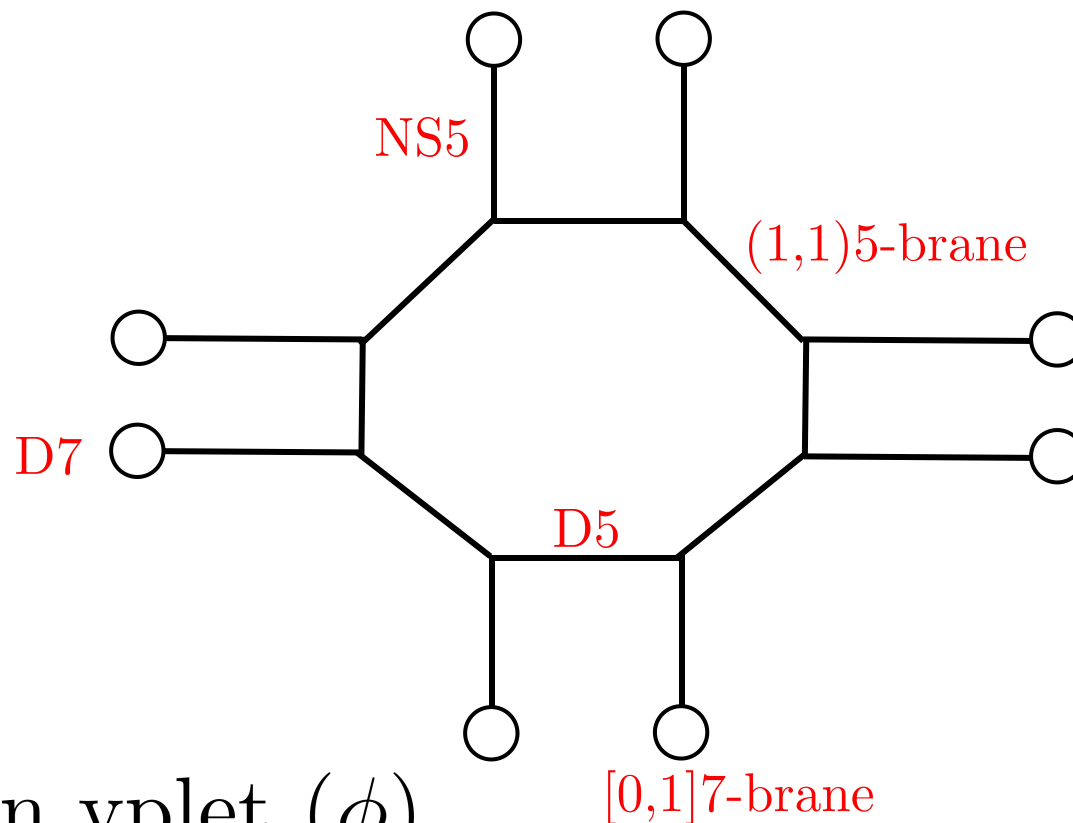

Shrinking of hexagon

→ Parameterize VEV of scalar in vplet (ϕ)

→ Parameterize Coulomb branch

Set masses of hypermultiplets to zero

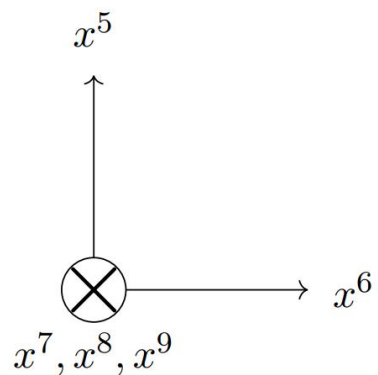
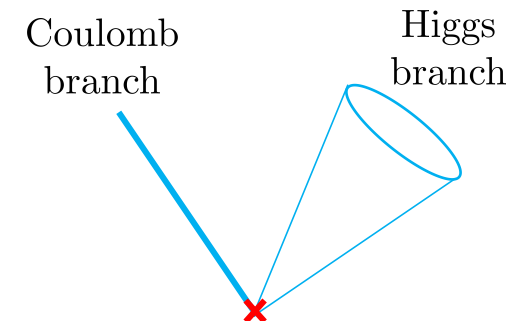
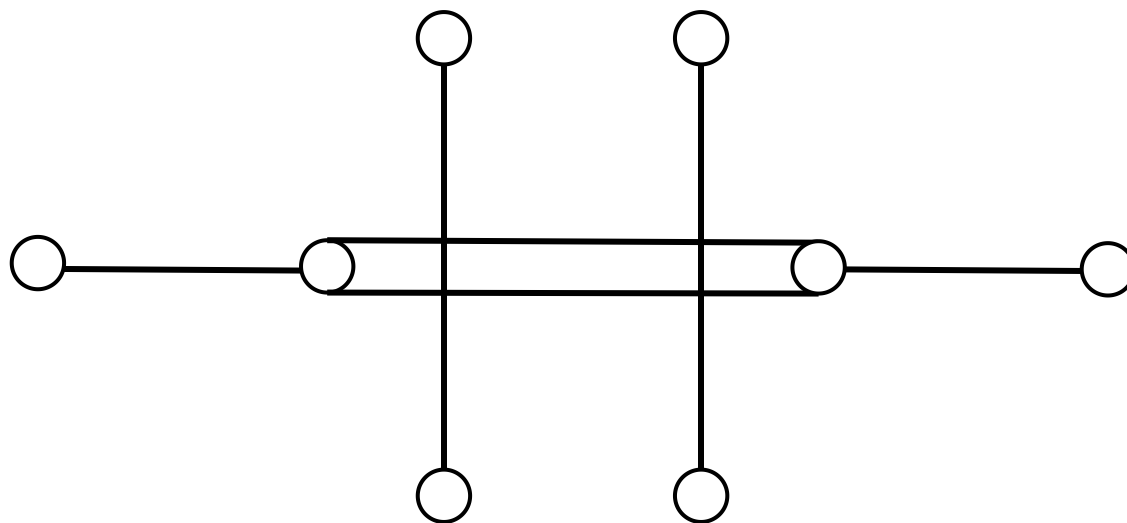

Entering the Higgs branch

5-branes moving along with 7-branes

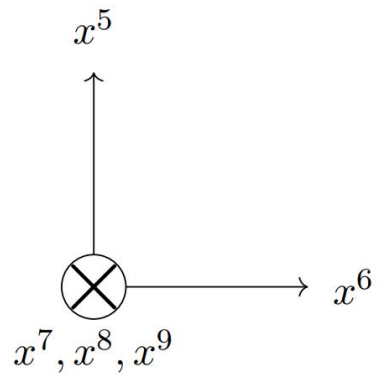
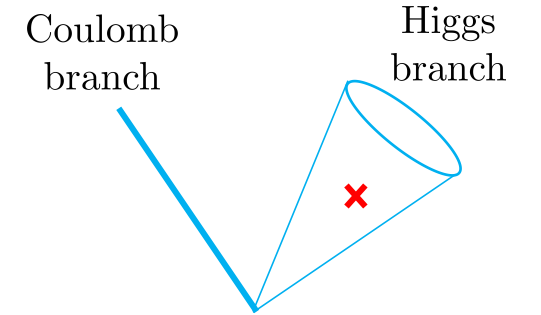
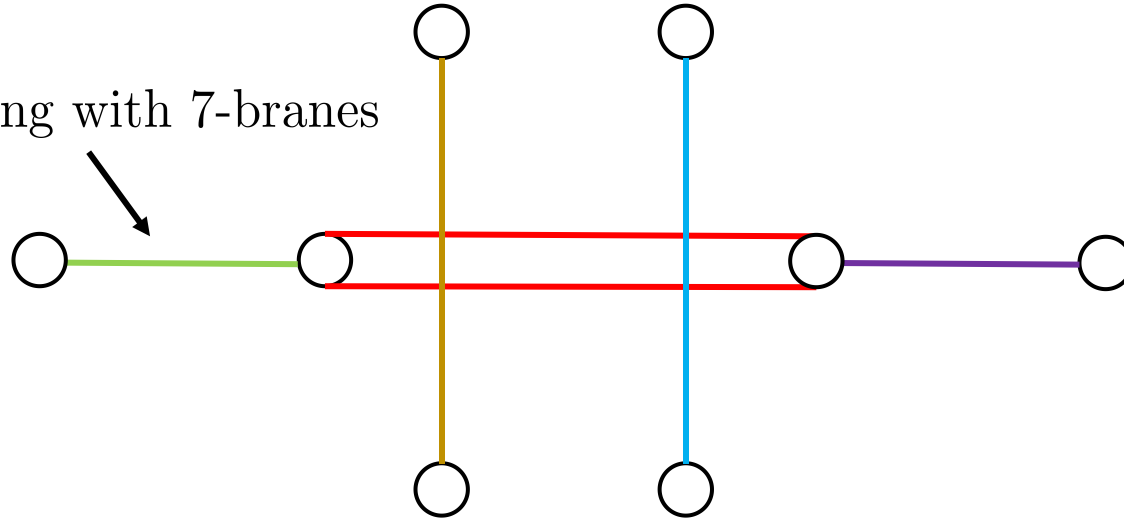

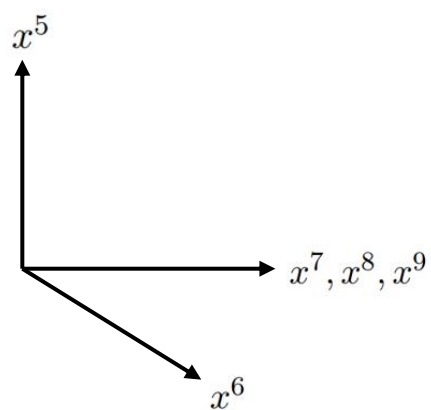

- 5-branes moving along 7-branes
- Parameterize VEV of scalar in hypers (q, \tilde{q}^\dagger)
- **Parameterize Higgs branch**

Entering the Higgs branch

Subweb moves along with 7-branes

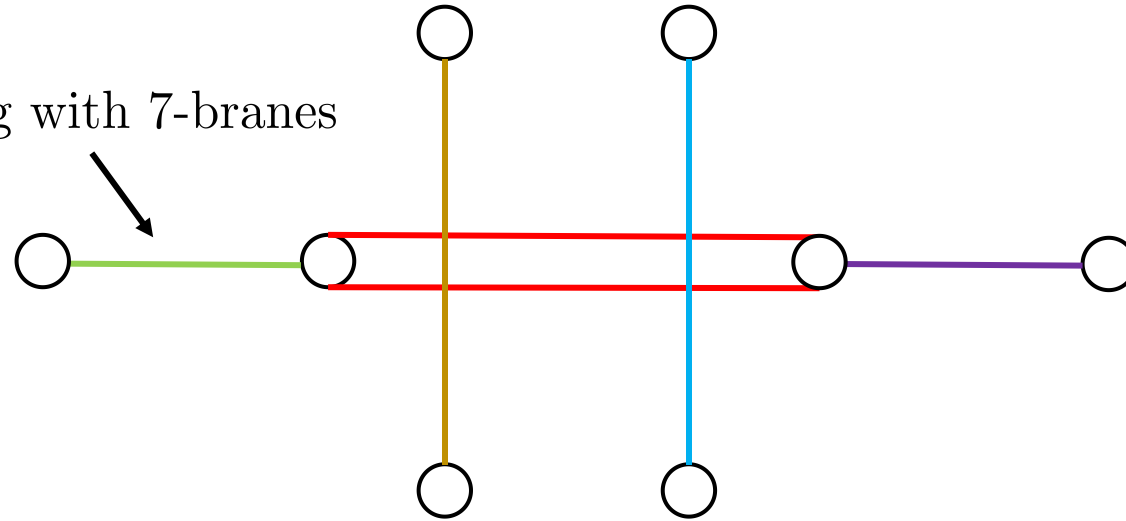

Magnetic Quiver:

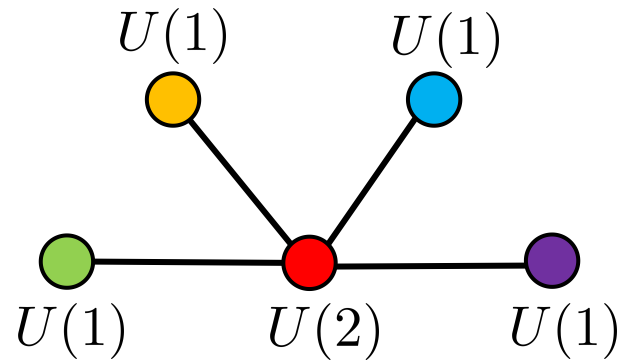

[Cabrera-Hanany-Yagi 2018]

*Need to calculate intersection number

Finite gauge coupling

$5d \mathcal{N} = 1$
Gauge theory (g_{fin})

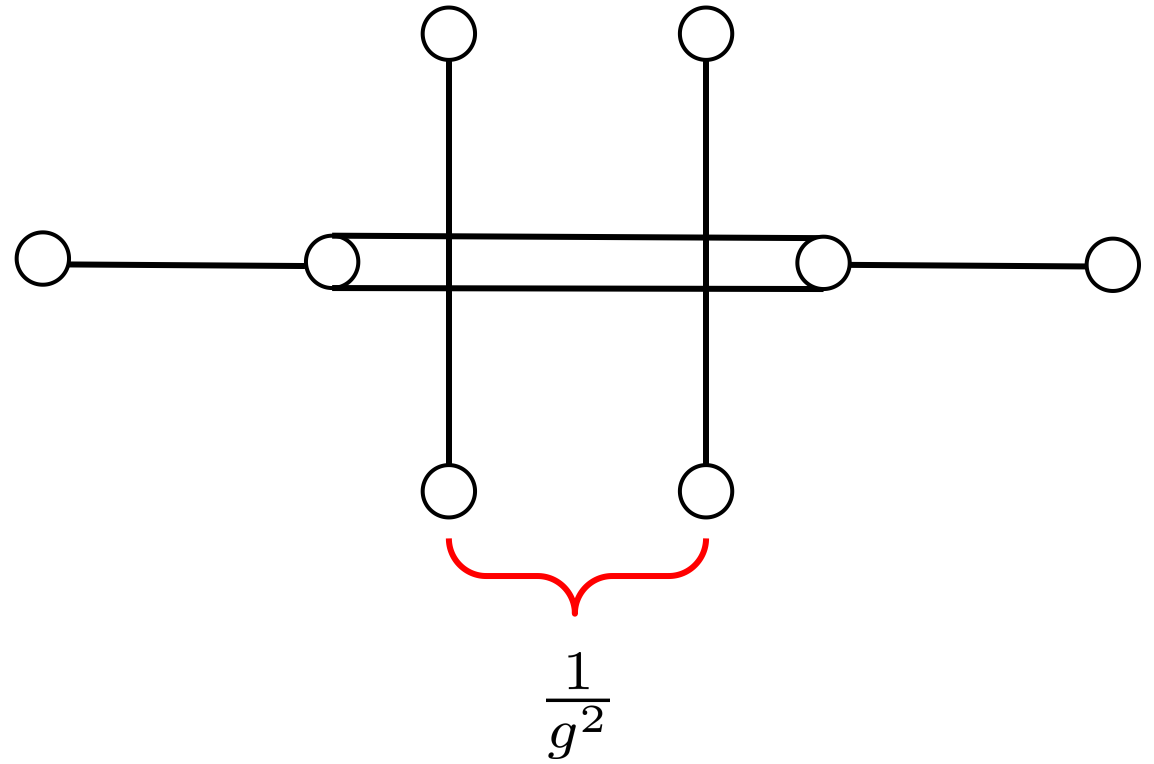
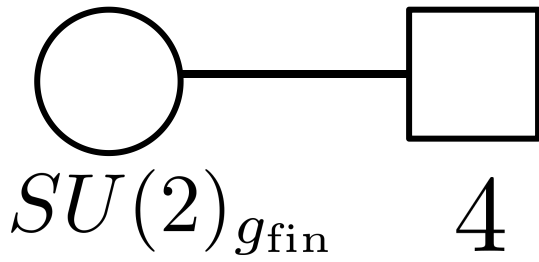

Go to UV fix point ($g \rightarrow \infty$)

$5d \mathcal{N} = 1$
SCFT (g_∞)

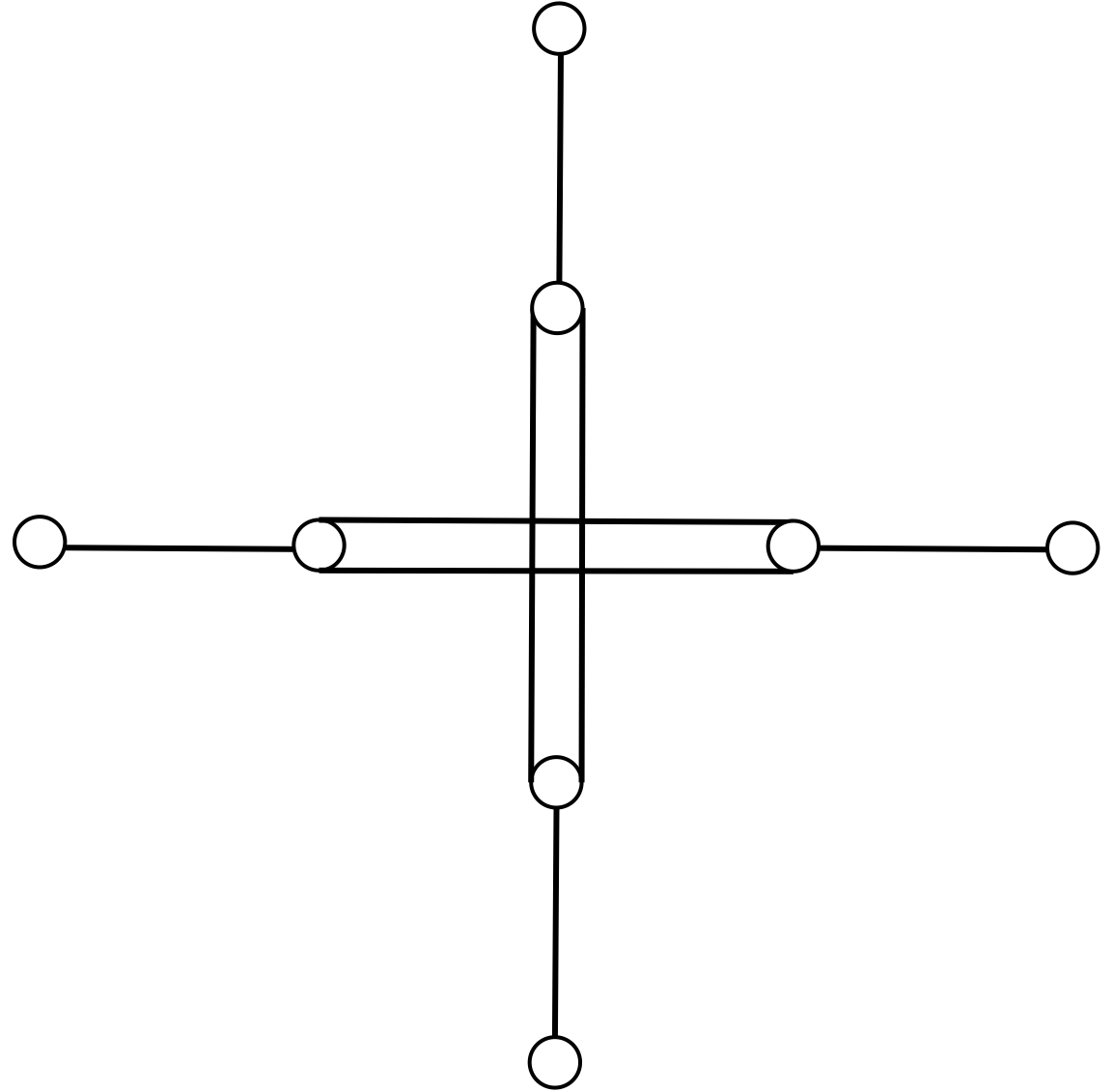
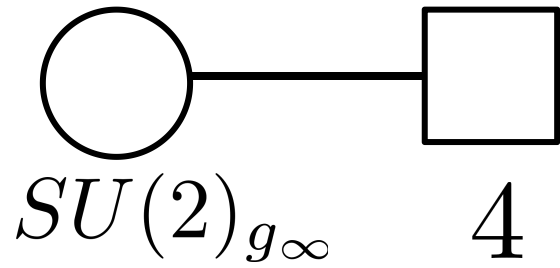

Maximal Decomposition

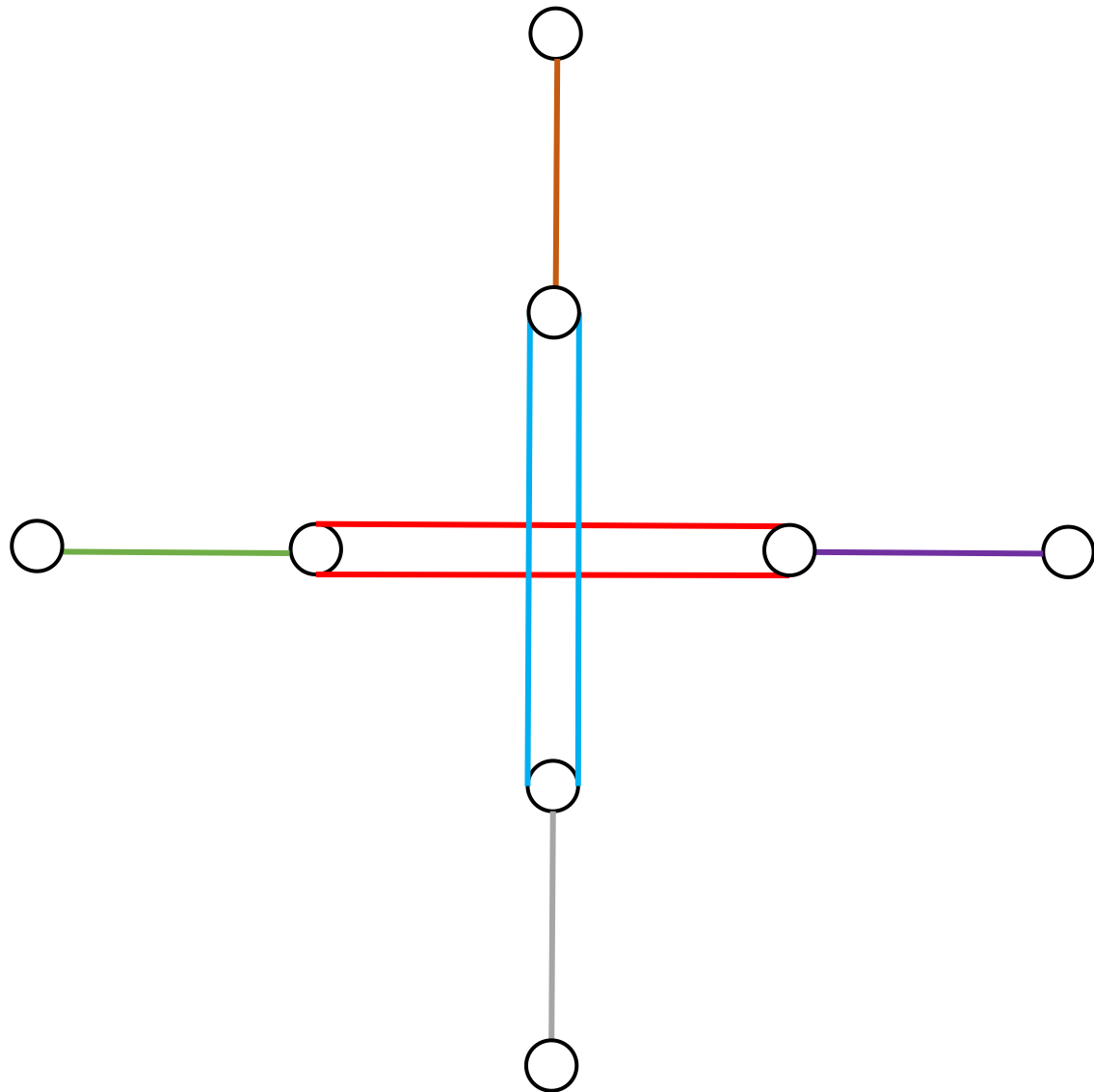

Magnetic Quiver:

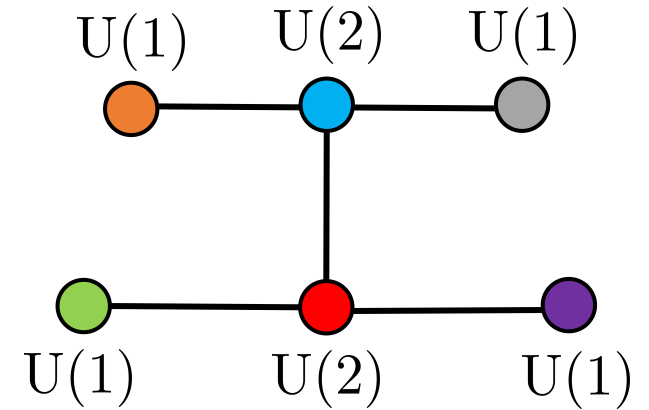

$5d \mathcal{N} = 1$
SCFT (g_∞)

Global Symmetry

Magnetic Quiver

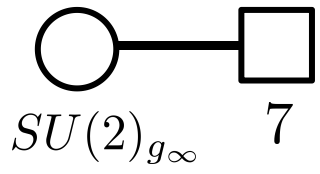

E_8

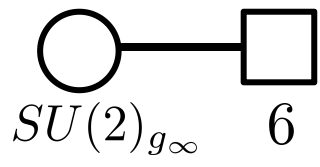
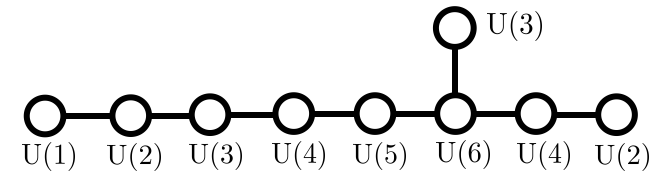

E_7

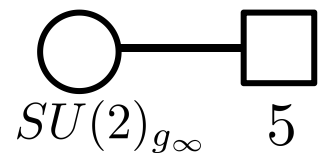
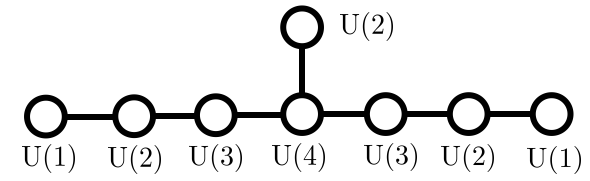

E_6

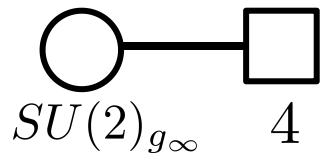
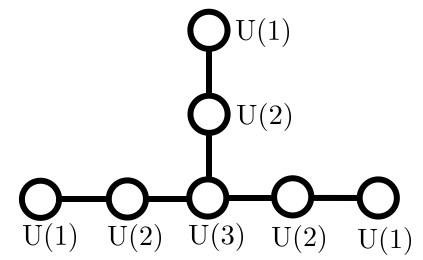

$E_5 \cong D_5$

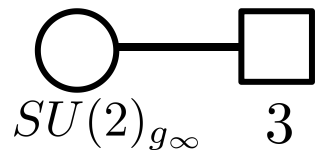
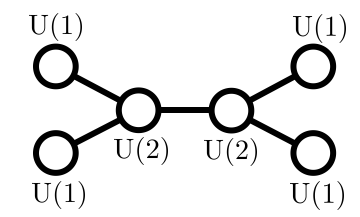

$E_4 \cong A_4$

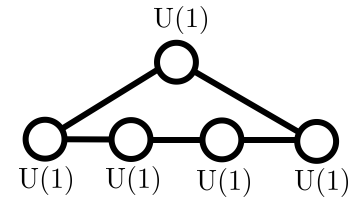

[Seiberg '96]
[Intrilligator-Seiberg '96]

$$SU(2) \cong Sp(1)$$

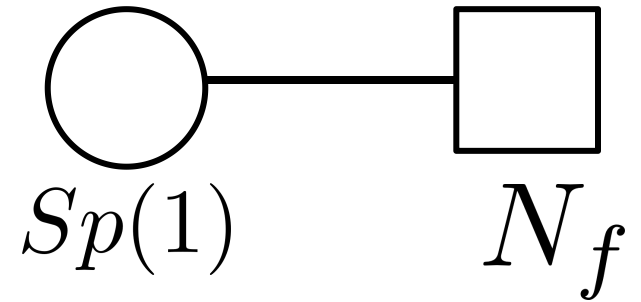
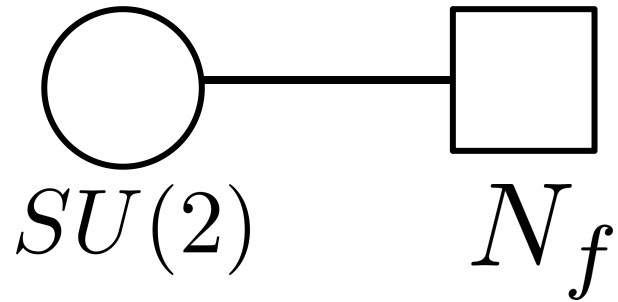

Orthosymplectic Quiver

5d $\mathcal{N} = 1$
 Gauge theory (g_{fin})

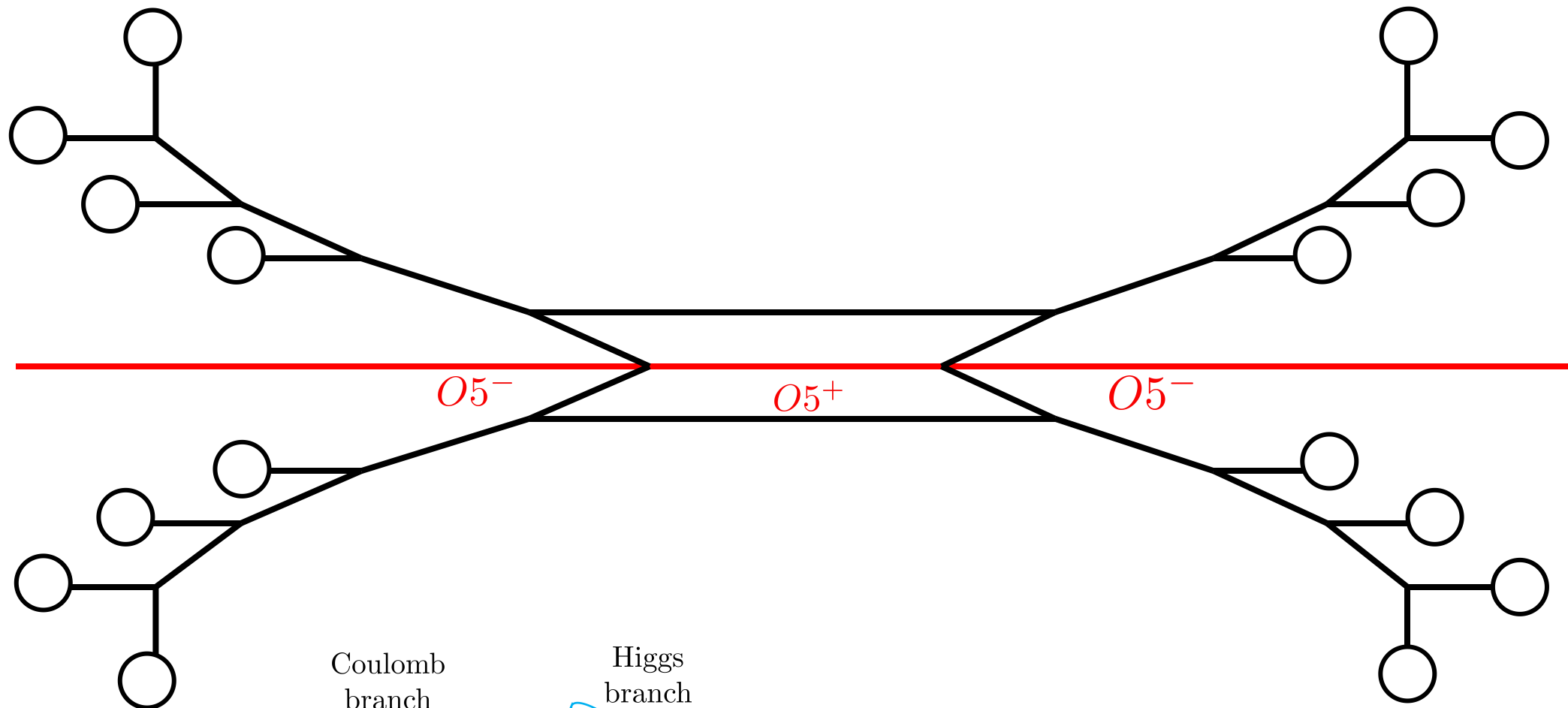
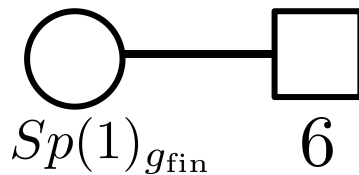

Coulomb
branch

Higgs
branch

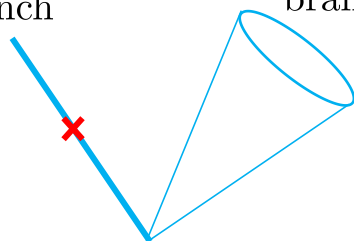

[Zafrir ' 15] [Hayashi-Kim-Lee-Yagi ' 18]
 [Bourget-Grimminger-Hanany-Sperling-ZZ ' 20]
 [Akhond-Carta-Dwivedi-Hayashi-Kim-Yagi ' 20]

$5d \mathcal{N} = 1$
 Gauge theory (g_{fin})

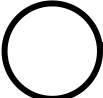

 $Sp(1)_{g_{\text{fin}}}$

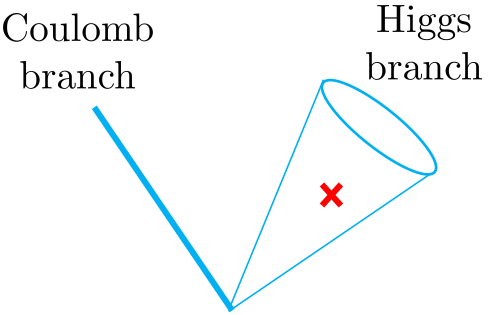
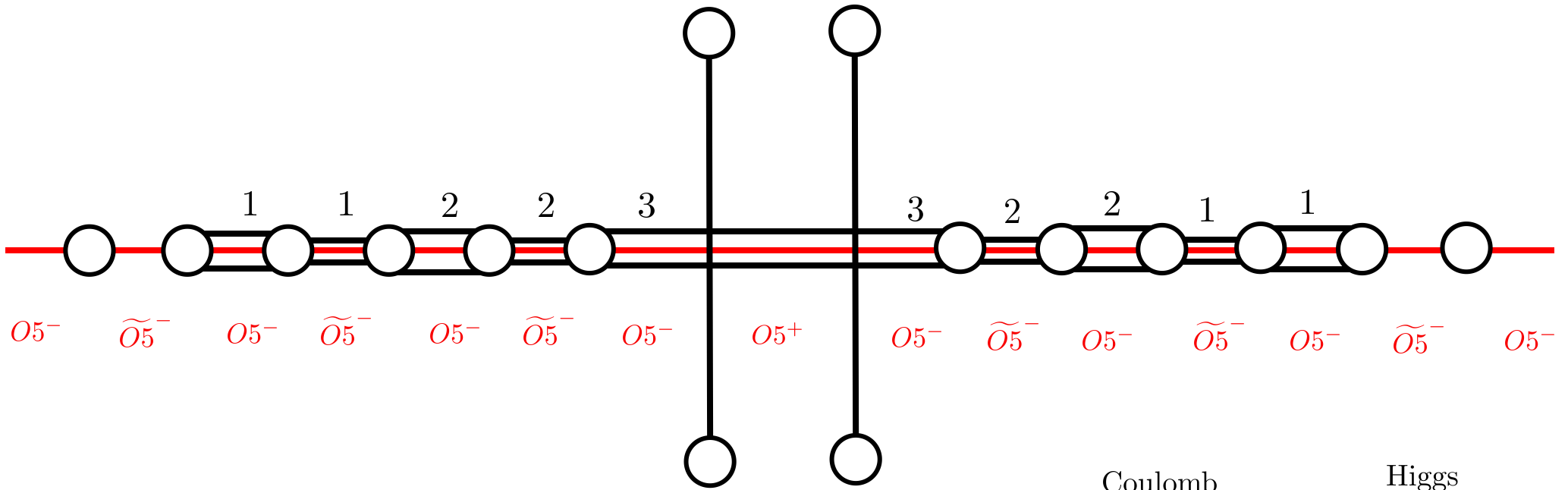
 6

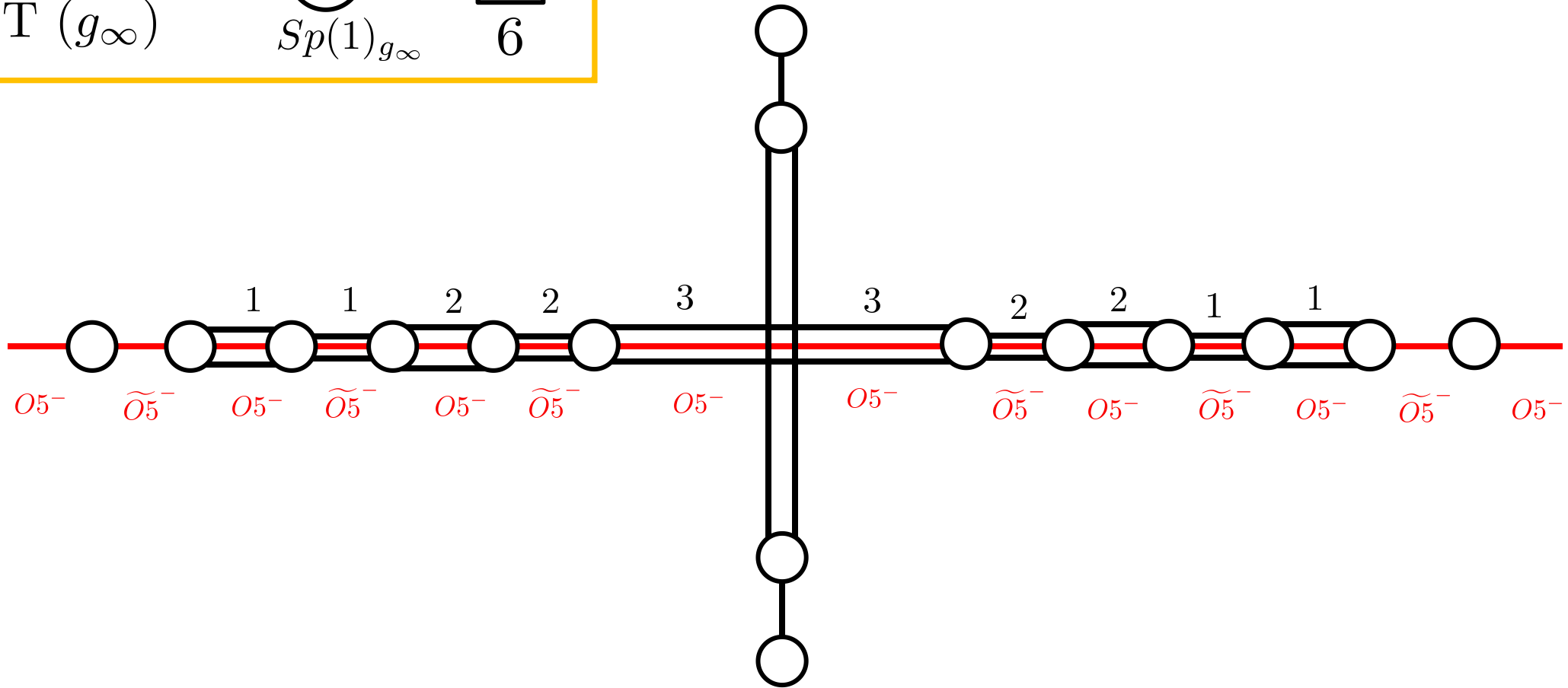
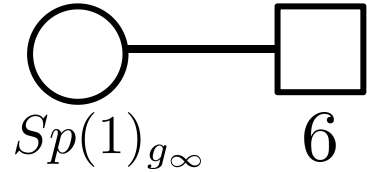

Going to infinite gauge coupling (g_∞)

$5d \mathcal{N} = 1$
SCFT (g_∞)



Reading the magnetic quiver

Orientifold	Gauge group
$O5^-$	$SO(\text{odd})$
$O5^+$	Sp
$\widetilde{O5}^+$	Sp
$\widetilde{O5}^-$	$SO(\text{even})$

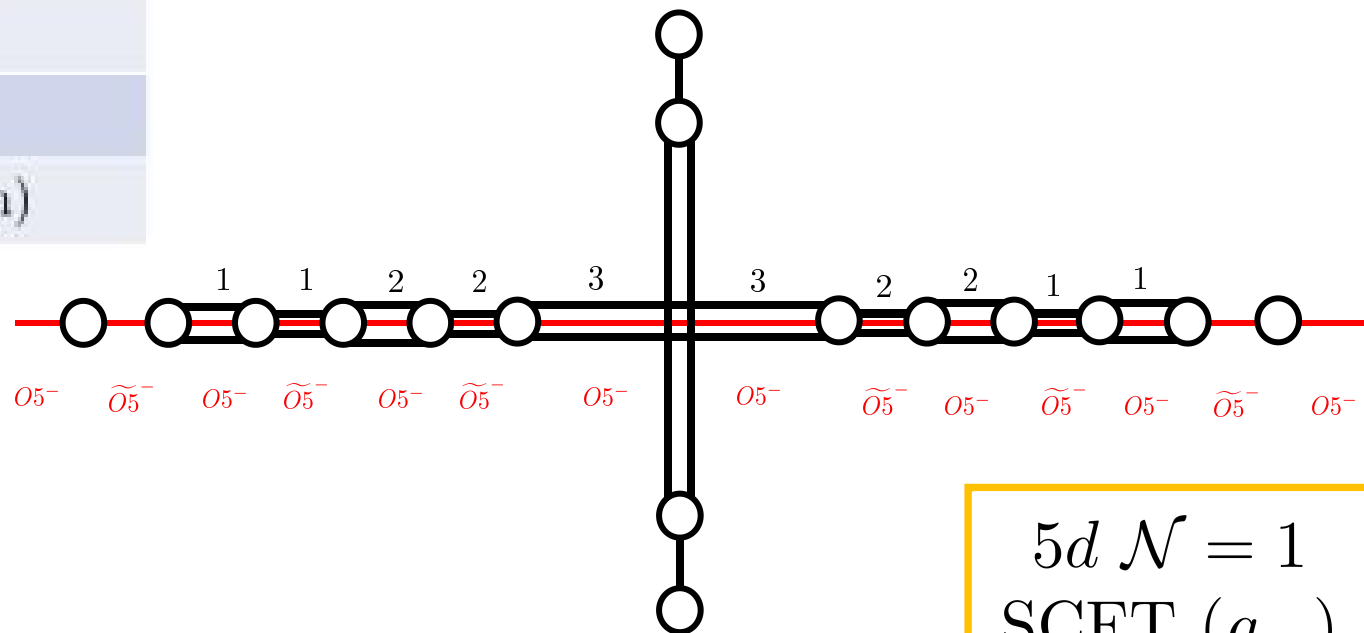

$5d \mathcal{N} = 1$
 SCFT (g_∞)

$Sp(1)_{g_\infty}$ 6

Magnetic Quiver:

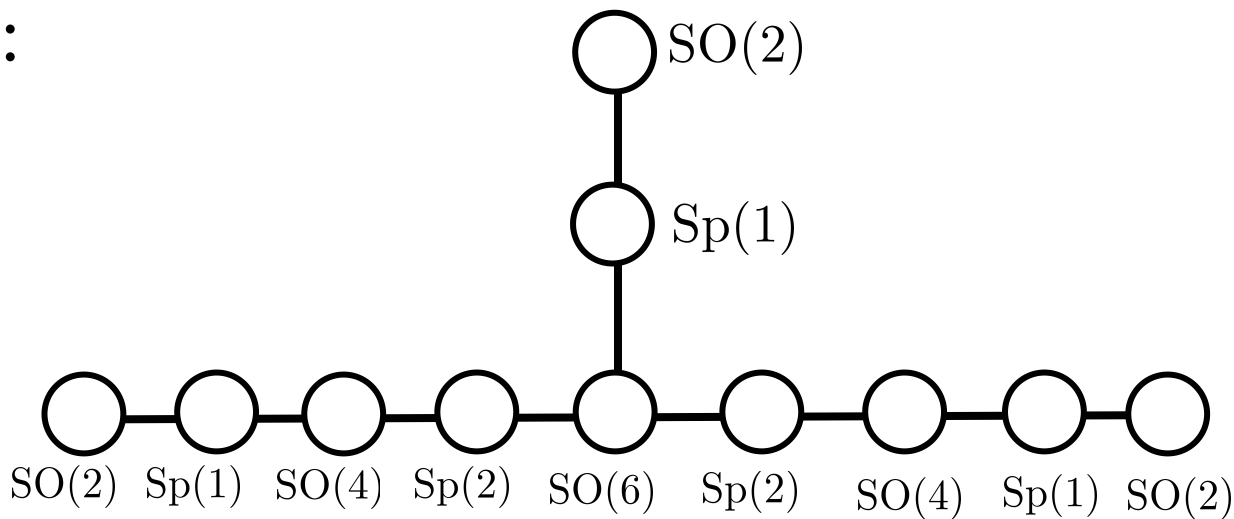

5d $\mathcal{N} = 1$
SCFT (g_∞)

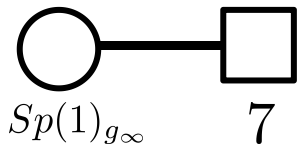

E_8

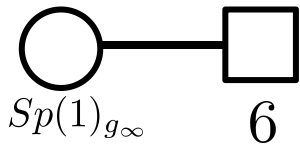

E_7

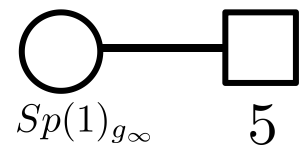

E_6

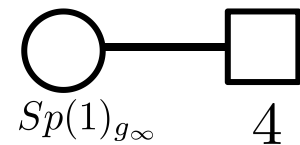

$E_5 \cong D_5$

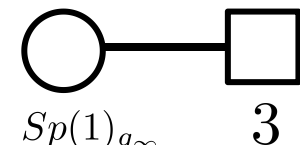

$E_4 \cong A_4$

Magnetic Quiver

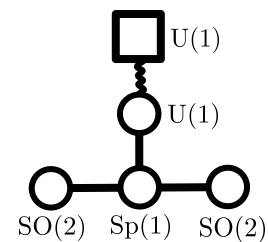
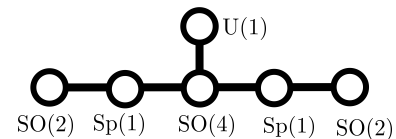
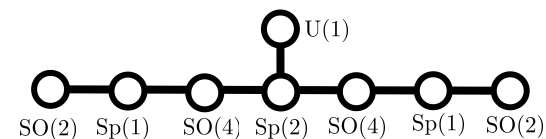
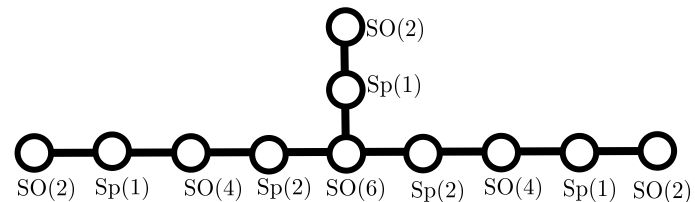
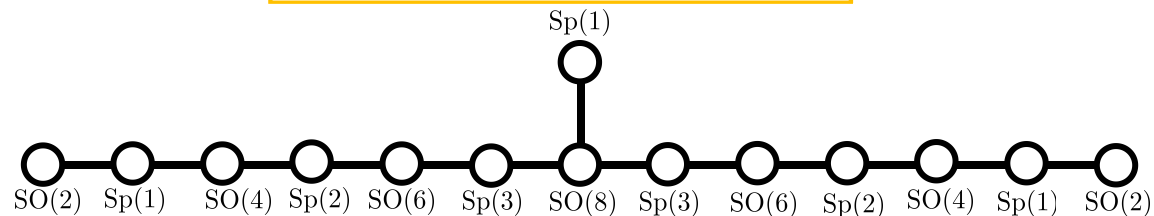

Magnetic Quiver (Unitary)

E_8

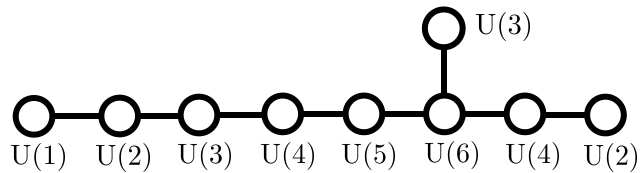

E_7

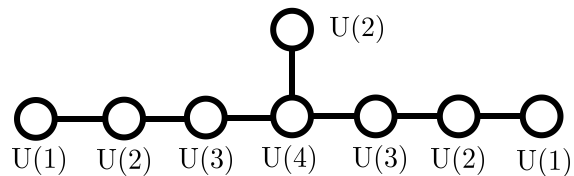

E_6

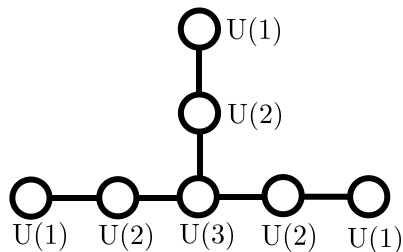

$E_5 \cong D_5$

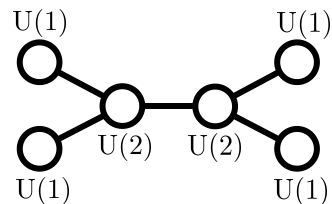

$E_4 \cong A_4$

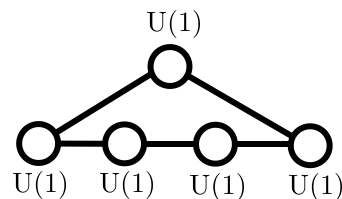

Magnetic Quiver (Unitary-Orthosymplectic)

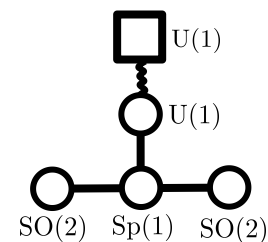
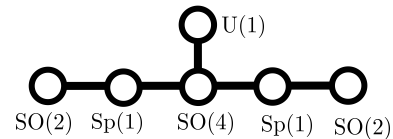
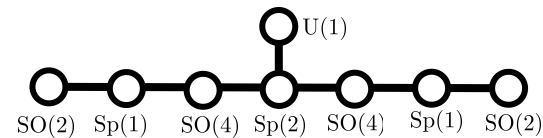
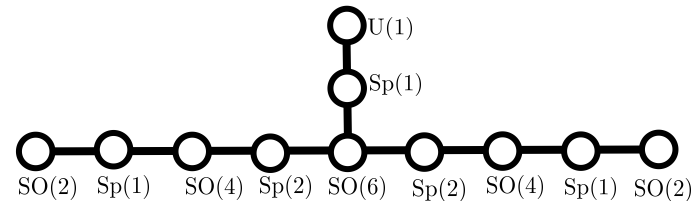
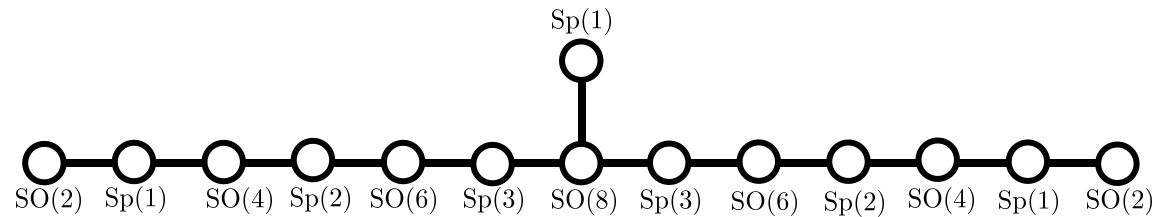

Coulomb^{3d} N=4

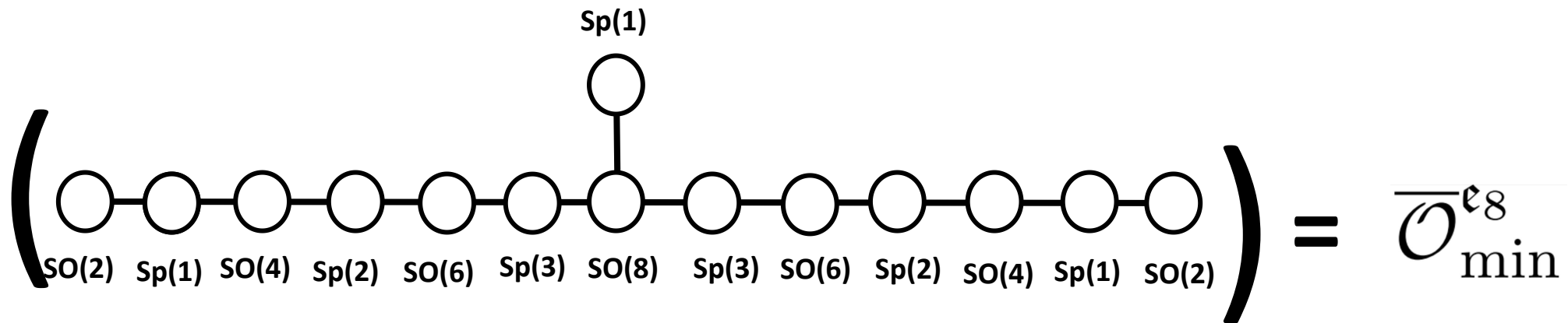

$= \overline{\mathcal{O}}_{\min}^{e_8}$





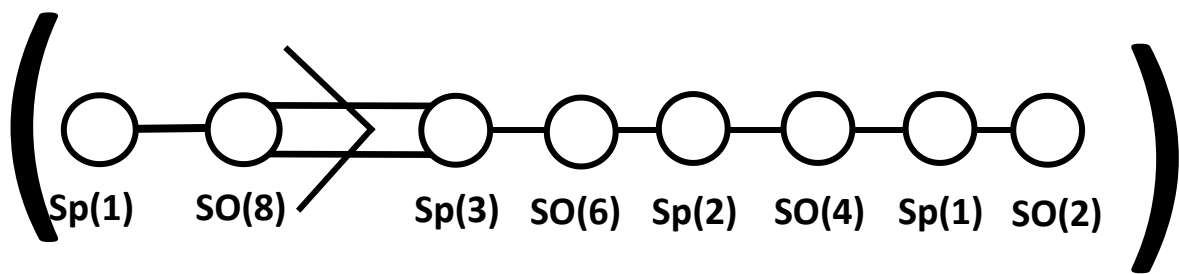



\mathbb{Z}_2 Folding

Coulomb^{3d} N=4

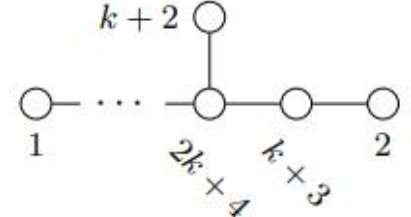
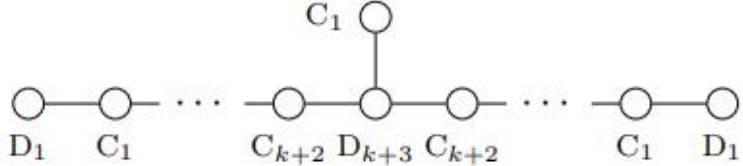

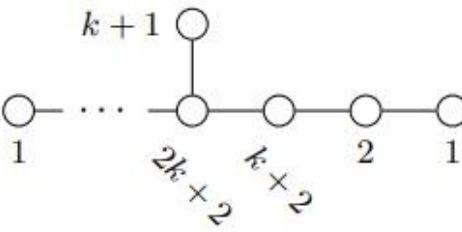
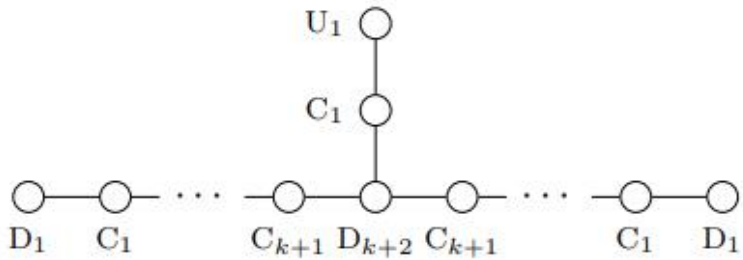
$= \overline{\mathcal{O}}_{\min}^{e_7}$

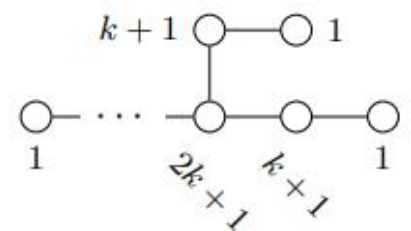
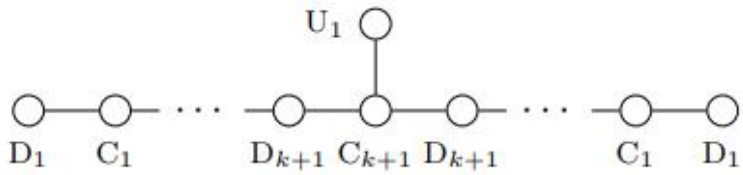
Generalization to entire families

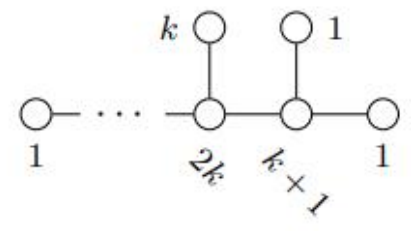
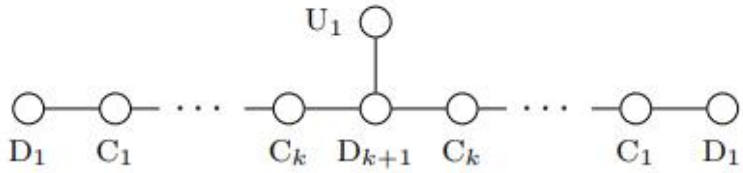
Family	Theory SU	Theory Sp	Magnetic quiver U	Magnetic quiver OSp
E_8	$2k+5$  $SU(k+1)_{\pm\frac{1}{2}}$	D_{2k+5}  $Sp(k)$		
E_7	$2k+4$  $SU(k+1)_{\pm 1}$	D_{2k+4}  $Sp(k)$		
E_6	$2k+3$  $SU(k+1)_{\pm\frac{3}{2}}$	D_{2k+3}  $Sp(k)$		
E_5	$2k+2$  $SU(k+1)_{\pm 2}$	D_{2k+2}  $Sp(k)$		

Generalization to entire families

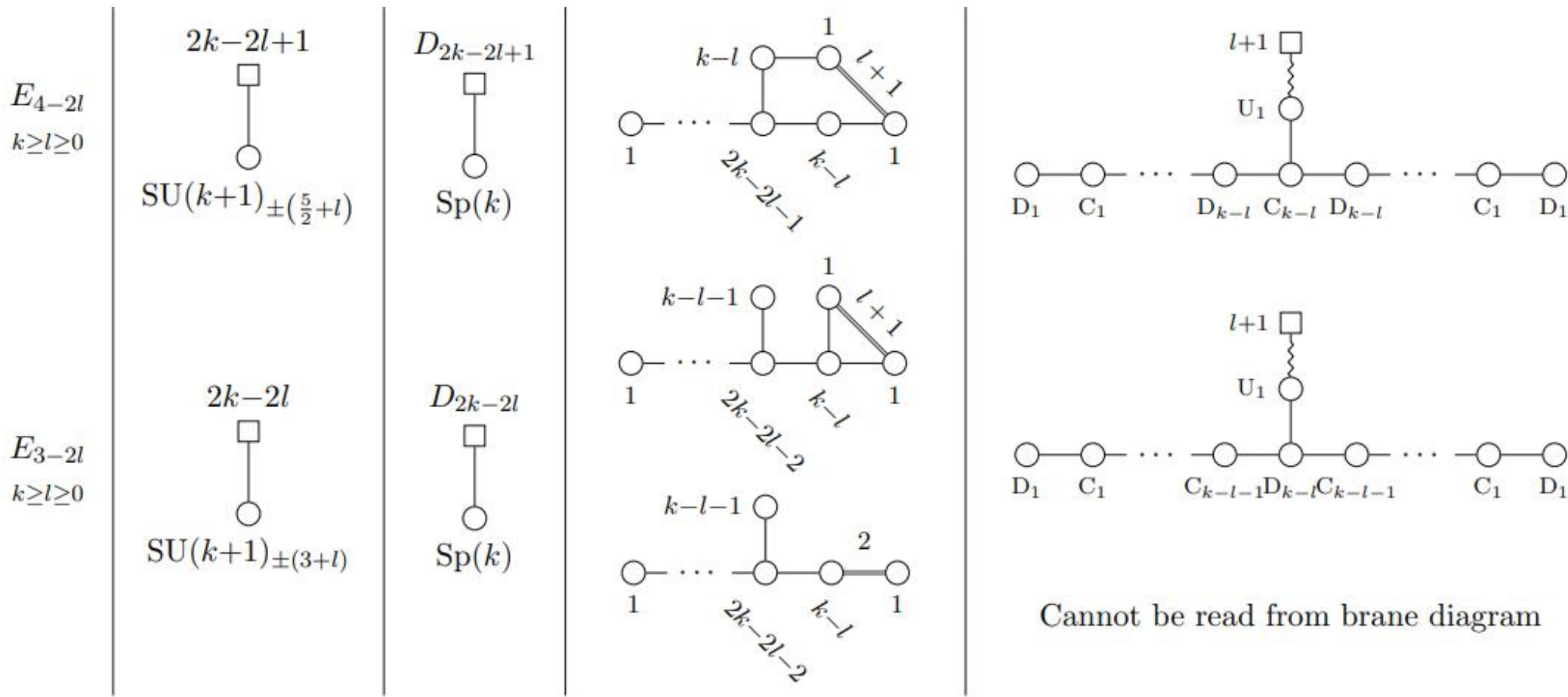

With Magnetic Quivers, what do we learn about the Higgs branch of the $5d \mathcal{N} = 1$ SCFT?

Using **recently developed tools**:

- With **Quiver Subtraction**, we probe the geometry of the Higgs branch (Stratification)
- With **Monopole Formula**, we probe the BPS spectrum of the Higgs branch

THANK YOU FOR LISTENING

